

S P E C F I L E



Product Number : **PT-EX12K**

Product Name : LCD Projector

Specifications

Main unit

Power supply		200–240 V AC, 11 A, 50/60 Hz
Power consumption		940 W (945 VA) (17 W in STANDBY MODE)
LCD panel	Panel size	46 mm (1.8 inches) diagonal (4:3 aspect ratio)
	Display method	Transparent LCD panel (× 3, R/G/B)
	Pixels	786,432 (1,024 × 768) × 3, total of 2,359,296 pixels
	Pixel configuration	Stripe × 1
Pure color control device		× 1
Lens		Optional powered zoom/focus lenses
Lamp		380 W UHM lamp × 2
Screen size		1.02–15.24 m (40–600 inches) diagonally, 4:3 aspect ratio (2.54–15.24 m (100–600 inches) with the ET-ELS03, 4:3 aspect ratio)
Brightness*1		13,000 lumens (two-lamp, NORMAL/AUTO MODE, with ET-ELS03)
Center-to-corner uniformity*1		90%
Contrast*1		4,000:1 (full on/full off, two-lamp, AUTO MODE)
Resolution		1,024 × 768 pixels (Input signals that exceed this resolution will be converted to 1,024 × 768 pixels.)
Scanning frequency	HDMI/DVI-I	fH: 26 kHz–80 kHz, fV: 23 Hz–85 Hz, dot clock: 162 MHz or lower
	RGB	fH: 15 kHz–120 kHz, fV: 48 Hz–120 Hz, dot clock: 230 MHz or lower
	YPbPr (YCbCr)	525i (480i): fH 15.75 kHz; fV 60 Hz, 625i (576i): fH 15.63 kHz; fV 50 Hz, 525p (480p): fH 31.50 kHz; fV 60 Hz, 625p (576p): fH 31.25 kHz; fV 50 Hz, 750 (720)/60p: fH 45.00 kHz; fV 60 Hz, 750 (720)/50p: fH 37.50 kHz; fV 50 Hz, 1035/60i: fH 33.75 kHz; fV 60 Hz, 1125 (1080)/60i: fH 33.75 kHz; fV 60 Hz, 1125 (1080)/50i: fH 28.13 kHz; fV 50 Hz, 1125 (1080)/25p: fH 28.13 kHz; fV 25 Hz, 1125 (1080)/25sF: fH 28.13 kHz; fV 50 Hz, 1125 (1080)/24p: fH 27.00 kHz; fV 24 Hz, 1125 (1080)/24sF: fH 27.00 kHz; fV 48 Hz, 1125 (1080)/30p: fH 33.75 kHz; fV 30 Hz, 1125 (1080)/30sF: fH 33.75 kHz; fV 60 Hz, 1125 (1080)/60p: fH 67.50 kHz; fV 60 Hz, 1125 (1080)/50p: fH 56.25 kHz; fV 50 Hz
	Video/S-Video	fH: 15.75 kHz, fV: 60 Hz [NTSC/NTSC4.43/PAL-M/PAL60] fH: 15.63 kHz, fV: 50 Hz [PAL/PAL-N/SECAM]
Optical axis shift		Powered, ET-ELW06 Vertical: ±39% from center of screen ET-ELW02/ELW04/ELS03/ELM01/ELT02/ELT03 Vertical: ±39% from center of screen, Horizontal: ±10% from center of screen ET-ELS02 Vertical: ±50% from center of screen, Horizontal: ±10% from center of screen ET-ELW03 Optical axis shift function cannot be operated.
Keystone correction range		Vertical: ±40° (ET-ELS03, with vertical correction only) Horizontal: ±40° (ET-ELS03, with horizontal correction only)
Installation		Ceiling/desk, front/rear

Terminals	INPUT 1	Menu selection
	HDMI IN	HDMI 19-pin × 1, Deep Color, HDCP compatible 525i (480i), 625i (576i), 525p (480p), 625p (576p), 750 (720)/60p, 750 (720)/50p, 1035/60i, 1125 (1080)/60i, 1125 (1080)/50i, 1125 (1080)/25p, 1125 (1080)/25sF, 1125 (1080)/24p, 1125 (1080)/24sF, 1125 (1080)/30p, 1125 (1080)/30sF, 1125 (1080)/60p, 1125 (1080)/50p, VGA (640 × 480)–WUXGA*2 (1,920 × 1,200)
	DVI-D IN	DVI-D 29-pin × 1, DVI 1.0 compliant, compatible with HDCP, compatible with single link only 525i (480i), 625i (576i), 525p (480p), 625p (576p), 750 (720)/60p, 750 (720)/50p, 1035/60i, 1125 (1080)/60i, 1125 (1080)/50i, 1125 (1080)/25p, 1125 (1080)/25sF, 1125 (1080)/24p, 1125 (1080)/24sF, 1125 (1080)/30p, 1125 (1080)/30sF, 1125 (1080)/60p, 1125 (1080)/50p, VGA (640 × 480)–WUXGA*2 (1,920 × 1,200)
	RGB IN R, G, B	D-sub HD 15-pin (female) × 1 G: 0.7 Vp-p (1.0 Vp-p for sync on G), 75 ohms; B, R: 0.7 Vp-p, 75 ohms; HD/VD, SYNC: high impedance, TTL (positive/negative) NOTE: SYNC/HD and VD terminals do not accept tri-level sync signals.
	INPUT 2	Menu selection
	RGB IN R, G, B	BNC × 5 (RGB/YPbPr/YCbCr × 1) G: 0.7 Vp-p (1.0 Vp-p for sync on G), 75 ohms; B, R: 0.7 Vp-p, 75 ohms; HD/VD, SYNC: high impedance, TTL (positive/negative) NOTE: SYNC/HD and VD terminals do not accept tri-level sync signals.
	Y, Pb (Cb), Pr (Cr)	Y: 1.0 Vp-p (including sync signal); Pb (Cb), Pr (Cr): 0.7 Vp-p, 75 ohms
	VIDEO IN	BNC × 1, 1.0 Vp-p, 75 ohms
	S-VIDEO IN	Mini DIN 4-pin × 1, Y: 1.0 Vp-p; C: 0.286 Vp-p, 75 ohms
	SERIAL IN	D-sub 9-pin (female) × 1, for external control (RS-232C compliant)
	SERIAL OUT	D-sub 9-pin (male) × 1, for link control
	REMOTE 1 IN	M3 jack × 1 for wired remote control
	LAN	RJ-45 × 1, for network connection, 100Base-TX/10Base-T, compliant with PLink™
	USB*3	USB type-B (USB connector) × 1 × 2 (INPUT 3/4)
Optional board slot	With ET-MD16SD1 installed	
	SERIAL IN (SDI IN 1/2)	BNC × 2 SD-SDI signal (YCbCr 4:2:2 10-bit), SMPTE 259M compliant: 480i, 576i Single-link HD-SDI signal (YPbPr 4:2:2 10-bit), SMPTE 292M compliant: 720/60p, 720/50p, 1035/60i, 1080/50i, 1080/60i, 1080/25p, 1080/25sF, 1080/24p, 1080/24sF, 1080/30p, 1080/30sF
	SERIAL OUT (SDI OUT)	BNC × 1, active through
Power cord length		3.0 m (9 ft 10 in)
Cabinet materials		Molded plastic (PC)
Dimensions (W × H × D)		538.5 mm × 268 mm*4 × 757 mm (21-7/32 × 10-9/16*4 × 29-13/16 inches) (without lens)
Weight		Approximately 28 kg (61.7 lbs) (without lens)
Operation noise		42 dB (LAMP POWER: NORMAL/ECO 2), 39 dB (LAMP POWER: ECO 1)
Operating temperature		0–40 °C (32–104 °F) up to 1,400 m (4,593 ft) above sea level, 0–30 °C (32–86 °F) between 1,400 m and 2,700 m (4,593 ft and 8,858 ft) above sea level.
Operating humidity		20%–80% (no condensation)

Remote control unit

Power supply	3 V DC (R03/LR03/AAA type battery × 2)
Operation range*5	Approximately 5 m (16 ft 5 in) when operated from directly in front of the signal receptor
Dimensions (W × H × D)	48 × 145 × 27 mm (1-7/8" × 5-23/32" × 1-1/16")
Weight	Approx. 102 g (3.6 oz) (including batteries)

Supplied accessories

Power cord × 1 (× 2 for PT-EX16KE)
Power cord holder/power cord cover (× 1 set)
Wireless/wired remote control unit (× 1)
Batteries for remote control (AAA/R03/LR03 type × 2)
Computer cable (× 1)
Software CD-ROM (Logo Transfer Software, Multi Projector Monitoring & Control Software, Real Color Manager Pro) (× 1)
Lens attachment (× 1 set)
Lens lock lever fixing bracket (× 1 set)
Lightshielding plate (× 3 set)
Spacer (× 1 set)
Cable tie (× 3)

Optional accessories

Zoom lens (1.2–1.5:1)	ET-ELW06
Zoom lens (1.4–1.8:1)	ET-ELW02
Zoom lens (1.5–2.0:1)	ET-ELW04
Zoom lens (2.0–2.6:1)	ET-ELS02
Zoom lens (2.6–3.5:1)	ET-ELS03
Zoom lens (3.5–4.5:1)	ET-ELM01
Zoom lens (4.4–6.2:1)	ET-ELT02
Zoom lens (6.3–9.0:1)	ET-ELT03
Fixed focus lens (0.8:1)	ET-ELW03
HD/SD-SDI board	ET-MD16SD1
Ceiling mount bracket	ET-PKE16H (for high ceilings) ET-PKE16S (for low ceilings)
Bracket assembly	ET-PKE12B
Replacement lamp unit	ET-LAE12
Replacement filter unit	ET-RFE12

Weights and dimensions shown are approximate. Specifications subject to change without notice.

- *1 Measurement, measuring conditions, and method of notation all comply with ISO 21118 international standards.
- *2 WUXGA resolution is supported only when the signals are compliant with VESA CVT-RB (Coordinated Video Timing-Reduced Blanking).
- *3 This port is for use by service personnel only. The USB interface may not operate with all USB compatible equipment.
- *4 With legs at shortest position.
- *5 Operation range differs depending on environments.

Dimensions

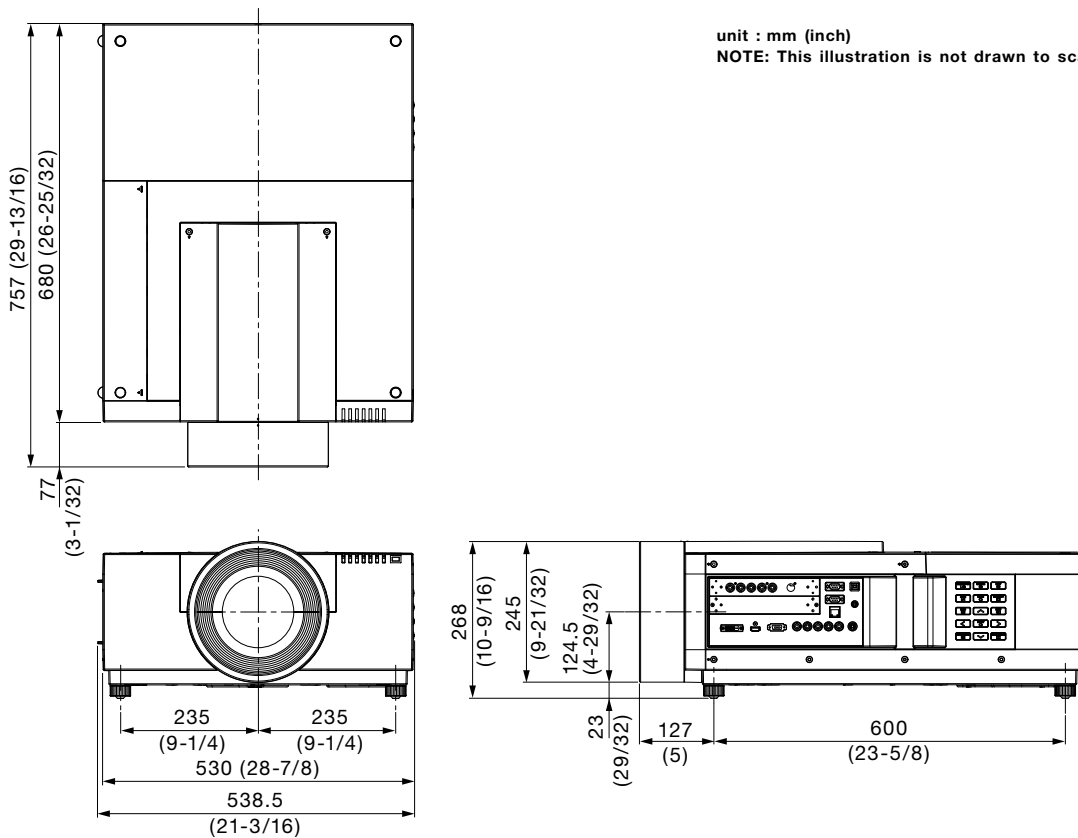

Terminals

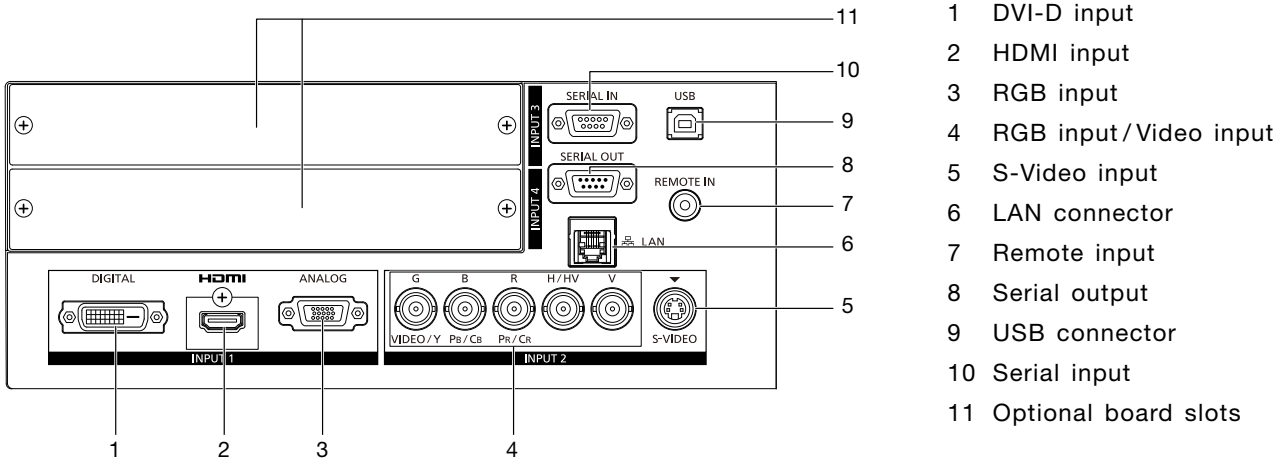

Standard setting-up position

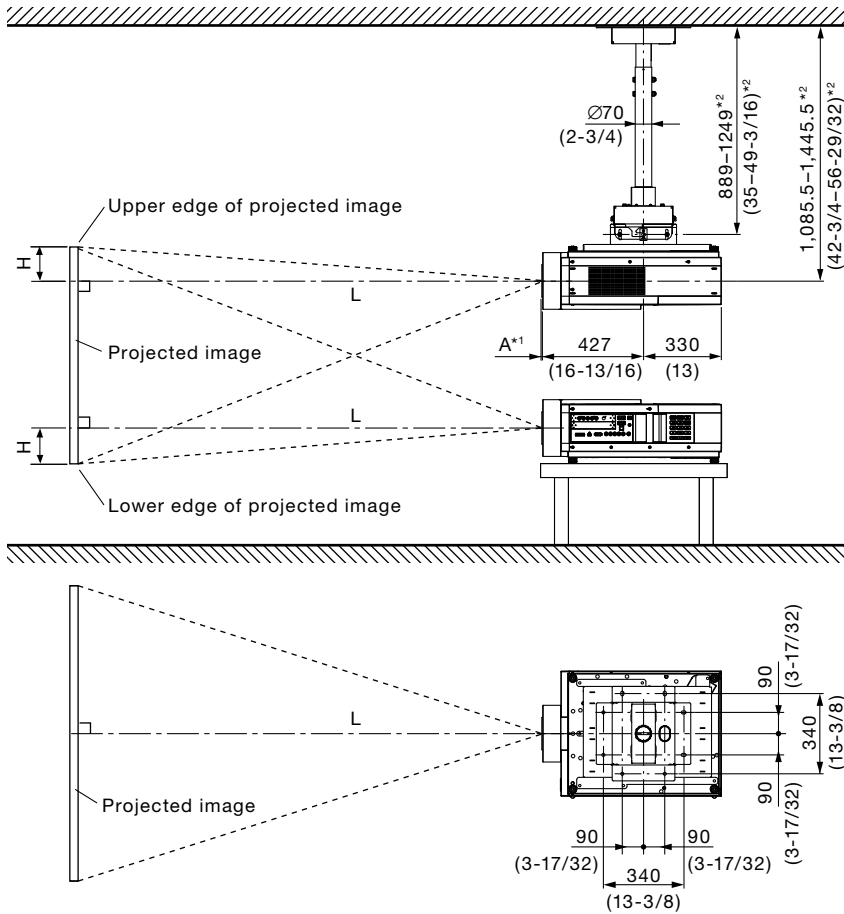

- *1 When the lens protrudes to the maximum.
 A: 0 mm (0") with the ET-ELW06/ELW02/ELW04/ELS02/ELM01/ELT02/ELW03
 6 mm (1/8") with the ET-ELS03
 217 mm (8-9/16") with the ET-ELT03
- *2 Adjustable in 60 mm (2-3/8") steps.

NOTE:

Illustrations show the projector installed using optional ceiling mount bracket ET-PKE16H and bracket assembly ET-PKE12B.

This illustration is not drawn to scale.

unit : mm (inch)

Projection distance for 4:3 aspect ratio screen

unit: meters

Screen size (diagonal)	Distance to screen (L)																
	Zoom															Fixed-focus	
	ET-ELW06 Zoom lens		ET-ELW02 Zoom lens		ET-ELW04 Zoom lens		ET-ELS02 Zoom lens		ET-ELS03 Zoom lens		ET-ELM01 Zoom lens		ET-ELT02 Zoom lens		ET-ELT03 Zoom lens		ET-ELW03 Fixed-focus lens
[m] / [in]	min.	max.	min.	max.	min.	max.	min.	max.	min.	max.	min.	max.	min.	max.	min.	max.	
1.02 / 40	0.91	1.17	1.07	1.42	1.15	1.56	1.48	1.99	-	-	2.87	3.69	3.75	5.11	5.27	7.58	0.60
1.27 / 50	1.16	1.49	1.36	1.80	1.47	1.98	1.90	2.53	-	-	3.56	4.58	4.63	6.35	6.50	9.38	0.77
1.52 / 60	1.40	1.81	1.65	2.18	1.79	2.40	2.32	3.08	-	-	4.26	5.48	5.51	7.58	7.73	11.19	0.94
1.78 / 70	1.65	2.12	1.94	2.56	2.12	2.82	2.74	3.63	-	-	4.95	6.38	6.39	8.82	8.96	13.00	1.10
2.03 / 80	1.89	2.44	2.23	2.93	2.44	3.24	3.16	4.18	-	-	5.65	7.28	7.27	10.05	10.19	14.80	1.27
2.29 / 90	2.13	2.76	2.52	3.31	2.76	3.66	3.58	4.72	-	-	6.34	8.18	8.14	11.28	11.42	16.61	1.44
2.54 / 100	2.38	3.08	2.81	3.69	3.08	4.08	4.00	5.27	5.22	7.10	7.04	9.08	9.02	12.52	12.65	18.42	1.60
3.05 / 120	2.87	3.71	3.39	4.44	3.72	4.92	4.85	6.36	6.30	8.56	8.42	10.88	10.78	14.99	15.11	22.03	1.94
3.81 / 150	3.60	4.66	4.26	5.57	4.69	6.18	6.11	8.00	7.92	10.73	10.51	13.57	13.42	18.69	18.80	27.45	2.44
5.08 / 200	4.82	6.25	5.71	7.46	6.29	8.28	8.21	10.74	10.61	14.36	13.98	18.07	17.82	24.86	24.94	36.49	3.27
6.35 / 250	6.04	7.83	7.16	9.35	7.90	10.38	10.32	13.47	13.31	18.00	17.45	22.56	22.22	31.03	31.09	45.52	4.10
7.62 / 300	7.26	9.42	8.61	11.23	9.51	12.48	12.42	16.21	16.00	21.63	20.92	27.05	26.62	37.20	37.24	54.55	4.94
10.16 / 400	9.69	12.59	11.51	15.00	12.72	16.68	16.63	21.68	21.39	28.89	27.87	36.04	35.42	49.54	49.53	72.62	6.60
12.70 / 500	12.13	15.76	14.41	18.78	15.94	20.88	20.84	27.15	26.79	36.15	34.81	45.03	44.22	61.88	61.83	90.69	8.27
15.24 / 600	14.57	18.93	17.30	22.55	19.15	25.07	25.05	32.61	32.18	43.41	41.76	54.01	53.02	74.22	74.12	108.76	9.94

NOTE:

- The value for L (distance to screen) varies slightly depending on the zoom lens characteristics.
- At the shortest projection distance, the zoom lens characteristics may cause slight image distortion.
- When keystone correction is used, the image is corrected in the direction that reduces its projected size.

Projection distance for 4:3 aspect ratio screen

unit: feet

Screen size (diagonal)	Distance to screen (L)																	
	Zoom																	Fixed-focus
	ET-ELW06 Zoom lens		ET-ELW02 Zoom lens		ET-ELW04 Zoom lens		ET-ELS02 Zoom lens		ET-ELS03 Zoom lens		ET-ELM01 Zoom lens		ET-ELT02 Zoom lens		ET-ELT03 Zoom lens		ET-ELW03 Fixed-focus lens	
[m] / [in]	min.	max.	min.	max.	min.	max.	min.	max.	min.	max.	min.	max.	min.	max.	min.	max.		
1.02 / 40	3.0	3.8	3.5	4.7	3.8	5.1	4.9	6.5	-	-	9.4	12.1	12.3	16.8	17.3	24.9	2.0	
1.27 / 50	3.8	4.9	4.5	5.9	4.8	6.5	6.2	8.3	-	-	11.7	15.0	15.2	20.8	21.3	30.8	2.5	
1.52 / 60	4.6	5.9	5.4	7.2	5.9	7.9	7.6	10.1	-	-	14.0	18.0	18.1	24.9	25.4	36.7	3.1	
1.78 / 70	5.4	7.0	6.4	8.4	7.0	9.3	9.0	11.9	-	-	16.2	20.9	21.0	28.9	29.4	42.7	3.6	
2.03 / 80	6.2	8.0	7.3	9.6	8.0	10.6	10.4	13.7	-	-	18.5	23.9	23.9	33.0	33.4	48.6	4.2	
2.29 / 90	7.0	9.1	8.3	10.9	9.1	12.0	11.7	15.5	-	-	20.8	26.8	26.7	37.0	37.5	54.5	4.7	
2.54 / 100	7.8	10.1	9.2	12.1	10.1	13.4	13.1	17.3	17.1	23.3	23.1	29.8	29.6	41.1	41.5	60.4	5.2	
3.05 / 120	9.4	12.2	11.1	14.6	12.2	16.1	15.9	20.9	20.7	28.1	27.6	35.7	35.4	49.2	49.6	72.3	6.4	
3.81 / 150	11.8	15.3	14.0	18.3	15.4	20.3	20.0	26.2	26.0	35.2	34.5	44.5	44.0	61.3	61.7	90.1	8.0	
5.08 / 200	15.8	20.5	18.7	24.5	20.6	27.2	26.9	35.2	34.8	47.1	45.9	59.3	58.5	81.6	81.8	119.7	10.7	
6.35 / 250	19.8	25.7	23.5	30.7	25.9	34.1	33.9	44.2	43.7	59.1	57.3	74.0	72.9	101.8	102.0	149.3	13.5	
7.62 / 300	23.8	30.9	28.2	36.8	31.2	40.9	40.7	53.2	52.5	71.0	68.6	88.7	87.3	122.0	122.2	179.0	16.2	
10.16 / 400	31.8	41.3	37.8	49.2	41.7	54.7	54.6	71.1	70.2	94.8	91.4	118.2	116.2	162.5	162.5	238.3	21.7	
12.70 / 500	39.8	51.7	47.3	61.6	52.3	68.5	68.4	89.1	87.9	118.6	114.2	147.7	145.1	203.0	202.9	297.5	27.1	
15.24 / 600	47.8	62.1	56.8	74.0	62.8	82.3	82.2	107.0	105.6	142.4	137.0	177.2	174.0	243.5	243.2	356.8	32.6	

NOTE:

- The value for L (distance to screen) varies slightly depending on the zoom lens characteristics.
- At the shortest projection distance, the zoom lens characteristics may cause slight image distortion.
- When keystone correction is used, the image is corrected in the direction that reduces its projected size.

Projection distance for 4:3 aspect ratio screen:
Height from the edge of screen to center of lens (H)

unit: meters

unit: feet

Screen size (diagonal)	Height from the edge of screen to center of lens (H)				Screen size (diagonal)	Height from the edge of screen to center of lens (H)				
	Zoom lenses			Fixed-focus lens		Zoom lenses			Fixed-focus lens	
	ET-ELW06/ELW02/ELW04/ ELS03/ELM01/ELT02/ELT03		ET-ELS02	ET-ELW03		ET-ELW06/ELW02/ELW04/ ELS03/ELM01/ELT02/ELT03		ET-ELS02	ET-ELW03	
[m] / [in]	min.	max.	min.	max.	[m] / [in]	min.	max.	min.	max.	
1.02 / 40	0.07	0.55	0	0.61	0.31	1.02 / 40	0.2	1.8	0	2.0
1.27 / 50	0.09	0.68	0	0.77	0.39	1.27 / 50	0.3	2.2	0	2.5
1.52 / 60	0.11	0.82	0	0.92	0.46	1.52 / 60	0.4	2.7	0	3.0
1.78 / 70	0.12	0.95	0	1.07	0.54	1.78 / 70	0.4	3.1	0	3.5
2.03 / 80	0.14	1.09	0	1.22	0.61	2.03 / 80	0.5	3.6	0	4.0
2.29 / 90	0.16	1.23	0	1.38	0.69	2.29 / 90	0.5	4.0	0	4.5
2.54 / 100	0.17	1.36	0	1.53	0.77	2.54 / 100	0.6	4.5	0	5.0
3.05 / 120	0.21	1.63	0	1.83	0.92	3.05 / 120	0.7	5.3	0	6.0
3.81 / 150	0.26	2.04	0	2.29	1.15	3.81 / 150	0.9	6.7	0	7.5
5.08 / 200	0.34	2.72	0	3.05	1.53	5.08 / 200	1.1	8.9	0	10.0
6.35 / 250	0.42	3.40	0	3.81	1.91	6.35 / 250	1.4	11.2	0	12.5
7.62 / 300	0.51	4.07	0	4.58	2.29	7.62 / 300	1.7	13.4	0	15.0
10.16 / 400	0.68	5.43	0	6.10	3.05	10.16 / 400	2.2	17.8	0	20.0
12.70 / 500	0.84	6.79	0	7.62	3.81	12.70 / 500	2.8	22.3	0	25.0
15.24 / 600	1.01	8.14	0	9.15	4.57	15.24 / 600	3.3	26.7	0	30.0

NOTE:

- When keystone correction is used, the image is corrected in the direction that reduces its projected size.
- NOTE: When the fixed-focus lens ET-ELW03 is mounted, the optical lens shift function cannot be used.

Calculation of the projection distance

For a screen size different from the above, use the equation below to calculate the projection distance.

Aspect ratio 4:3

Zoom lenses

ET-ELW06	minimum	$L (m) = (\text{diagonal screen size in inches}) \times 0.024389 - 0.065097$
	maximum	$L (m) = (\text{diagonal screen size in inches}) \times 0.031710 - 0.099560$
ET-ELW02	minimum	$L (m) = (\text{diagonal screen size in inches}) \times 0.028982 - 0.089642$
	maximum	$L (m) = (\text{diagonal screen size in inches}) \times 0.037722 - 0.089627$
ET-ELW04	minimum	$L (m) = (\text{diagonal screen size in inches}) \times 0.032144 - 0.139232$
	maximum	$L (m) = (\text{diagonal screen size in inches}) \times 0.041988 - 0.123040$
ET-ELS02	minimum	$L (m) = (\text{diagonal screen size in inches}) \times 0.042086 - 0.208493$
	maximum	$L (m) = (\text{diagonal screen size in inches}) \times 0.054690 - 0.203992$
ET-ELS03	minimum	$L (m) = (\text{diagonal screen size in inches}) \times 0.053914 - 0.175760$
	maximum	$L (m) = (\text{diagonal screen size in inches}) \times 0.072616 - 0.163096$
ET-ELM01	minimum	$L (m) = (\text{diagonal screen size in inches}) \times 0.069440 + 0.086800$
	maximum	$L (m) = (\text{diagonal screen size in inches}) \times 0.089871 + 0.086816$
ET-ELT02	minimum	$L (m) = (\text{diagonal screen size in inches}) \times 0.087982 + 0.221978$
	maximum	$L (m) = (\text{diagonal screen size in inches}) \times 0.123396 + 0.173741$
ET-ELT03	minimum	$L (m) = (\text{diagonal screen size in inches}) \times 0.122945 + 0.350492$
	maximum	$L (m) = (\text{diagonal screen size in inches}) \times 0.180688 + 0.343253$

Fixed-focus lens

ET-ELW03	minimum	$L (m) = (\text{diagonal screen size in inches}) \times 0.016666 - 0.067361$
----------	---------	--

NOTE:

Distances calculated with the above equations will include a slight error.

Shift range

Optical axis shift function allows to shift the position of a projected image as shown below.

- When the ET-ELW06 is mounted

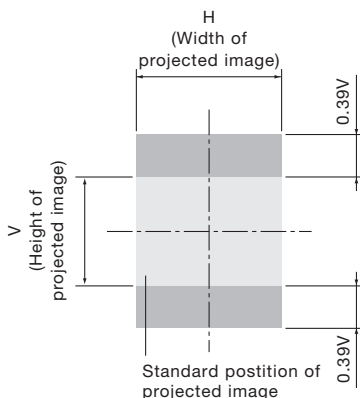

- When the ET-ELW02/ELW04/ELS03/ELM01/ELT02/ELT03 is mounted

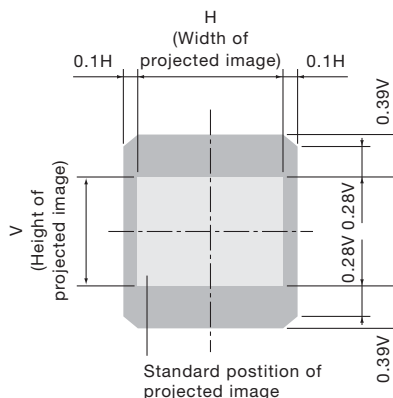

- When the ET-ELS02 is mounted

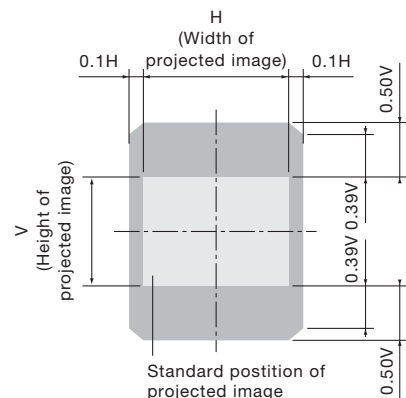

Installable angle

Install the projector at an angle within the range shown below.

• Vertical direction

The projector may be installed at a vertical angle of 360°.

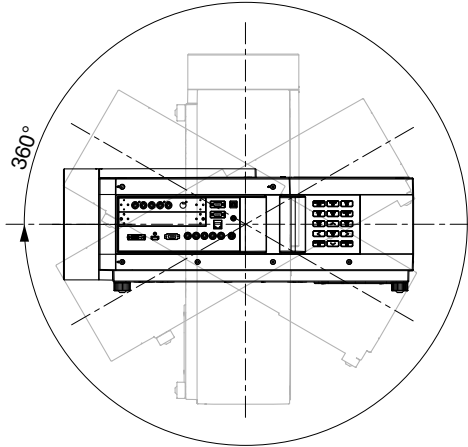
**• Horizontal direction**

The projector may be installed at a horizontal angle of $\pm 10^\circ$.

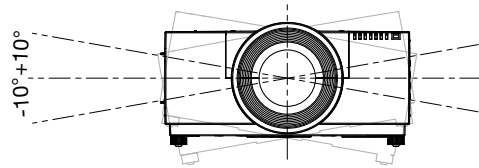

List of compatible signals

The signals that can be input to this projector are shown in the table below. Horizontal scanning frequencies of 15 kHz to 100 kHz (15 kHz to 120 kHz for RGB signals), vertical scanning frequencies of 24 Hz to 120 Hz (48 Hz to 120 Hz for RGB signals), and a dot clock of 162 MHz maximum (230 MHz maximum for RGB signals) can be input.

NOTE: The native resolution of this projector is 1,024 × 768 pixels. If the display resolution of the input signal is different from the native resolution, image compression or expansion will be used to convert the input signal to a level within the native resolution.

Display mode	Display resolution (dots)*1	Scanning frequency H (kHz)	Scanning frequency V (kHz)	Dot clock frequency (MHz)	Format
NTSC/NTSC4.43/PAL-M/PAL60	720 × 480i	15.7	59.9	–	VIDEO/S-VIDEO
PAL/PAL-N/SECAM	720 × 576i	15.6	50.0	–	
525i (480i)	720 × 480i	15.7	59.9	27.0	HDMI
625i (576i)	720 × 576i	15.6	50.0	27.0	
525p (480p)	720 × 480i	31.5	60.0	27.0	HDMI/DVI-D
625p (576p)	720 × 576i	31.3	50.0	27.0	
525i (480i)	640 × 480i	15.7	60.0	12.3	YPbPr/RGB
625i (576i)	768 × 576i	15.6	50.0	14.8	
525p (480p)	640 × 480	31.5	59.9	25.2	
625p (576p)	768 × 575	31.3	50.0	29.5	
720p	1280 × 720	37.5	50.0	74.3	HDMI/DVI-D/YPbPr/RGB
		45.0	60.0	74.3	
1035i	1920 × 1035i	33.8	60.0	74.3	
1080i	1920 × 1080i	28.1	50.0	74.3	
		33.8	60.0	74.3	
1080p	1920 × 1080	27.0	24.0	74.3	
		28.1	25.0	74.3	
		33.8	30.0	74.3	
		56.3	50.0	148.5	
		67.5	60.0	148.5	
1080psf/30		33.8	60.0	74.3	
1080psf/25		28.1	50.0	74.3	
1080psf/24		27.0	48.0	74.3	
VGA	640 × 400	31.5	70.1	28.3	RGB
	640 × 480	31.5	59.9	25.2	HDMI/DVI-D/RGB
		37.5	75.0	31.5	RGB
		37.9	72.8	31.5	
		37.9	74.4	31.5	
		43.3	85.0	36.0	
	720 × 400	31.5	70.1	25.1	
MAC LC13	640 × 480	35.0	66.6	31.3	
MAC13		35.0	66.7	30.2	
SVGA	800 × 600	32.7	51.1	32.7	
		34.5	55.4	36.4	
		35.2	56.3	36.0	
		37.9	60.3	40.0	HDMI/DVI-D/RGB
		37.9	61.0	40.0	RGB
		38.0	60.5	40.1	
		38.6	60.3	38.6	
		46.9	75.0	49.5	
		48.1	72.2	50.0	
		53.7	85.1	56.3	
MAC16	832 × 624	49.7	74.6	57.3	
XGA	1024 × 768	43.4	60.1	65.0	HDMI/DVI-D
		44.0	54.6	59.1	RGB
		46.9	58.2	63.0	
		47.0	58.3	61.7	
		48.4	60.0	65.0	
		48.5	60.0	65.2	
		58.0	72.0	74.7	
		56.5	70.1	75.0	
		60.0	75.0	78.8	
		60.3	74.9	79.3	
		61.0	75.7	81.0	
		62.0	77.1	84.4	
		63.5	79.4	83.4	
		68.7	85.0	94.5	
	1024 × 768i	35.5	87.0	44.9	
		36.0	87.2	47.3	
MAC19	1024 × 768	60.2	75.1	80.0	

*1 The "i" appearing after the resolution indicates an interlaced signal.

List of compatible signals

Display mode	Display resolution (dots)*1	Scanning frequency		Dot clock frequency (MHz)	Format
		H (kHz)	V (kHz)		
WXGA	1280 × 768	47.8	59.9	79.5	HDMI/DVI-D/RGB
		60.3	74.9	102.3	
		68.6	84.8	117.5	
	1280 × 800	41.2	50.0	68.6	HDMI/DVI-D
		49.6	60.1	79.4	
		49.7	59.8	83.5	
		58.3	70.0	98.9	
		56.0	70.0	95.0	
		57.7	72.0	97.8	
		60.0	72.0	102.8	
		62.8	74.9	106.5	
		64.0	60.0	108.0	
	1360 × 768	47.7	60.0	86.7	HDMI/DVI-D/RGB
		56.2	72.0	100.2	
	1366 × 768	46.5	50.0	67.4	HDMI/DVI-D
	1376 × 768	48.4	60.0	86.7	HDMI/DVI-D/RGB
	MAC21	1152 × 870	68.7	75.1	1000.0
SXGA	1152 × 900	64.2	70.4	94.6	HDMI/DVI-D/RGB
		61.2	65.2	92.0	
		61.9	66.0	94.5	
	1280 × 960	71.4	75.6	105.1	HDMI/DVI-D
		60.0	60.0	108.0	
	1280 × 1024	60.3	58.1	93.1	RGB
		62.5	58.6	108.0	
		63.3	60.0	108.2	
		63.4	60.0	111.5	
		63.7	60.0	109.5	
		63.8	60.2	108.2	
		63.9	60.0	107.4	
		64.0	60.0	108.0	
		71.7	67.2	117.0	
		77.0	72.0	130.1	
		80.0	75.0	135.0	
	1280 × 1024i	81.1	76.1	135.0	HDMI/DVI-D/RGB
91.1		85.0	157.5		
46.4		86.7	78.7		
MAC	1280 × 960	50.0	86.0	80.0	RGB
	1280 × 1024	50.0	94.0	80.0	
SXGA+	1400 × 1050	75.0	75.1	126.0	HDMI/DVI-D/RGB
		80.0	75.1	135.2	
		62.5	58.6	108.0	
		64.0	60.0	108.2	
		64.0	60.2	108.0	
		64.7	59.9	101.0	
		65.1	59.9	122.4	
		65.3	60.0	121.8	
65.4	60.1	122.9			
WXGA+	1440 × 900	55.9	59.9	106.5	RGB
		74.9	60.0	161.9	
UXGA	1600 × 1200	75.0	60.0	162.0	HDMI/DVI-D/RGB
UXGA*2		81.3	65.0	175.5	RGB
		87.5	70.0	189.0	
		93.8	75.0	202.5	
		106.3	85.0	229.5	
WSXGA+	1680 × 1050	65.3	60.0	146.3	HDMI/DVI-D/RGB
WUXGA	1920 × 1200	74.0	59.9	154.0	RGB
WUXGA*2		74.6	59.9	193.3	

*1 The "i" appearing after the resolution indicates an interlaced signal.
 *2 The "REAL" mode of "SCREEN" setting cannot be operated for these modes.

Serial connector

The serial connector complies with RS-232C. To control the projector from a personal computer, commands must be input through communication software, based on the format and satisfying the communication conditions shown below.

Pin assignments and signal names

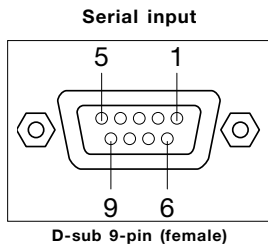

No.	Signal name	Description	No.	Signal name	Description
1	-	NC	6	-	NC
2	TXD	Transmitted data	7	CTS	Connected internally
3	RXD	Received data	8	RTS	Connected internally
4	-	NC	9	-	NC
5	GND	Ground			

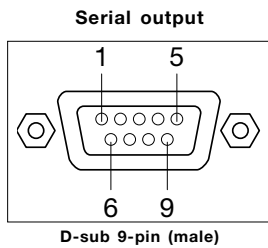

No.	Signal name	Description	No.	Signal name	Description
1	-	NC	6	-	NC
2	RXD	Received data	7	RTS	Connected internally
3	TXD	Transmitted data	8	CTS	Connected internally
4	-	NC	9	-	NC
5	GND	Ground			

Communication conditions (factory setting)

Signal level	RS-232C-compliant
Synchronization method	Start-stop synchronization
Baud rate	19,200 bps*
Parity	None
Character length	8 bits
Stop bit	1 bit
X parameter	None
S parameter	None

* 9,600 bps when "AMX D.D." is set to ON.

Basic format

Transmission from the computer begins with STX, then the ID, command, parameter, and ETX are sent in this order. Add parameters according to the details of control.

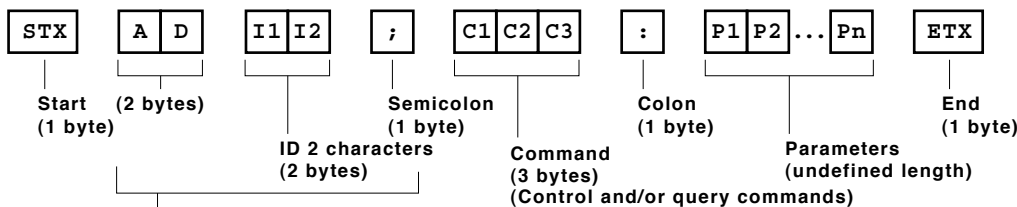

ID designator:
 01 to 06: Projector ID number
 ZZ: All units (ID ALL)

NOTE: STX and ETX are character codes. Expressed in hexidecimals, STX is 02 and ETX is 03.

CAUTION

- It may not be possible to send or receive commands for about 10 to 60 seconds when the lamp is first turned on. If this occurs, wait for 60 seconds, then try sending or receiving again.
- When sending multiple commands, be sure to wait for at least 0.5 second after receiving a response from the projector before sending the next command.
- Additional time is sometimes required for response due to processing inside the projector. Set the time-out period for command response to 10 seconds or more.
- When using two or more units, set different IDs for each unit.

Cable specifications

Projector		PC (DTE)	
1	NC	NC	1
2			2
3			3
4	NC	NC	4
5			5
6	NC	NC	6
7			7
8			8
9	NC	NC	9

Control commands

Command : Parameter	Function		Callback
PON	Standby power	On	PON
POF		Off	POF
IIS:HD1	Input	Input 1 [HDMI]	IIS:HD1
IIS:DVI		Input 1 [DVI (PC)]	IIS:DVI
IIS:DVI		Input 1 [DVI (AV HDCP)]	IIS:DVI
OED:1			OED:1
IIS:RG1		Input 1 [RGB (PC)]	IIS:RG1
IIS:SCT		Input 1 [RGB (Scart)]	IIS:SCT
IIS:RG2		Input 2 [RGB]	IIS:RG2
IIS:RG2		Input 2 [RGB(Y·P _B (C _B)·P _R (C _R))]	IIS:RG2
ORF:1			ORF:1
IIS:VID		Input 2 [Video]	IIS:VID
IIS:SVD	Input 2 [S-Video]	IIS:SVD	
IIS:AU1, SD1		Input 3 [SDI1] * with the ET-MD16SD1 only	IIS:AU1, SD1
IIS:AU1, SD2		Input 3 [SDI2] * with the ET-MD16SD1 only	IIS:AU1, SD2
IIS:AU2, SD1		Input 4 [SDI1] * with the ET-MD16SD1 only	IIS:AU2, SD1
IIS:AU2, SD2		Input 4 [SDI2] * with the ET-MD16SD1 only	IIS:AU2, SD2
LPM:0	Lamp mode	Two lamps	LPM:0
LPM:1		Single lamp (auto)	LPM:1
LPM:2		Single lamp (lamp 1)	LPM:2
LPM:3		Single lamp (lamp 2)	LPM:3
OLP:2	Lamp power	Auto	OLP:2
OLP:0		Normal	OLP:0
OLP:3		Eco 1	OLP:3
OLP:4		Eco 2	OLP:4
OSH:0	Shutter	Off	OSH:0
OSH:1		On	OSH:1
OFZ:1	Freeze	On	OFZ:1
OFZ:0		Off	OFZ:0
OAS	Auto setup		OAS
VSE:0	Screen (aspect)	Normal	VSE:0
VSE:6		Full	VSE:6
VSE:2		Wide (16:9)	VSE:2
VSE:40		Zoom	VSE:40
VSE:5		Real	VSE:5
VSE:50		Custom	VSE:50
VPM:STD	Picture	Standard	VPM:STD
VPM:DYN		Dynamic	VPM:DYN
VPM:CIN		Cinema	VPM:CIN
VPM:REA		Real	VPM:REA

*1 Do not send PON, POF or OSH commands continuously in a short period of time. Doing so may burst the lamp or shorten the lamp replacement cycle.

*2 When a command that cannot be executed during standby mode is sent, the projector will send an ER401 command in reply.

Status request commands

Command:Parameter	Function	Callback	Description
QPW	Main power status	000	Off
		001	On
QIN	Input signal status	HD1	Input 1 [HDMI]
		DVI	Input 1 [DVI (PC)]
QED		2	
		DVI	Input 1 [DVI (AV HDCP)]
QIN		1	
		RG1	Input 1 [RGB (PC)]
QIN		SCT	Input 1 [RGB (Scart)]
		RG2	Input 2 [RGB]
QED		0	
		RG2	Input 2 [RGB(Y·P _B (C _B)·P _R (C _R))]
QIN		1	
		VID	Input 2 [Video]
QIN		SVD	Input 2 [S-Video]
		AU1, SD1	Input 3 [SDI1] * with the ET-MD16SD1 only
QED		AU1, SD2	Input 3 [SDI2] * with the ET-MD16SD1 only
		AU2, SD1	Input 4 [SDI1] * with the ET-MD16SD1 only
QED		AU2, SD2	Input 4 [SDI2] * with the ET-MD16SD1 only
		0	
QSL	Lamp operation mode status	0	Two lamps
		1	Single lamp (auto)
		2	Single lamp (lamp 1)
		3	Single lamp (lamp 2)
QLP	Lamp power mode status	2	Auto
		0	Normal
		3	Eco 1
		4	Eco 2
QSH	Shutter function status	0	Off
		1	On
QFZ	Freeze function status	0	On
		1	Off
QSE	Aspect mode status	0	Normal
		6	Full
		2	Wide (16:9)
		40	Zoom
		5	Real
		50	Custom
QPM	Picture mode status	0	Normal
		6	Full
		STD	Standard
		DYN	Dynamic
QST	Projector run time	CIN	Cinema
		REA	Real
QSL: 1	Lamp 1 run time	p1p2p3p4p5	00000 – 99999 hours
QSL: 2	Lamp 2 run time	p1p2p3p4	0000 – 9999 hours
QSL: 3	Lamp 3 run time	p1p2p3p4	0000 – 9999 hours
QSL: 4	Lamp 4 run time	p1p2p3p4	0000 – 9999 hours
QTM: 0	Temperature status	p1p2p3p4/p5p6p7p8 *1	Air intake
QTM: 2		p1p2p3p4/p5p6p7p8 *1	Panel section

*1 p1p2p3p4 = Celsius (°C), p5p6p7p8 = Fahrenheit (°F)

NOTE: If a wrong command is received, the projector will send an ER401 or ER402 command to the computer.

Command example

To set the shutter function on, send the command as shown below.



NOTE: When sending commands without parameters, a colon (:) is not necessary.

Notes on projector placement and operation

The projector uses a high-wattage lamp that becomes very hot during operation. Please observe the following precautions.

1. Make sure there is an unobstructed space of 1,000 mm (3 feet 3 inches) or more around the projector.
2. Do not stack projector units directly on top of one another for the purpose of multiple (stacked) projection. When stacking projector units, be sure to provide the amount of space indicated below between them.
3. Make sure that nothing blocks the projector's air intake and exhaust openings. Also, install the projector so that cool or hot air from other air conditioning equipment does not flow directly toward the projector's air intake or exhaust openings.
4. Do not install the projector in an enclosed space. If it is necessary to install it in an enclosed space, add a separate ventilation system. If ventilation is insufficient, hot air will accumulate at the intake opening. This may cause the projector's protective circuit to interrupt projector operation.
5. If the projector is installed in an enclosed space, ensure that the projector's intake and exhaust openings are not blocked. Take particular care to ensure that hot air from the exhaust openings is not sucked into the intake openings.

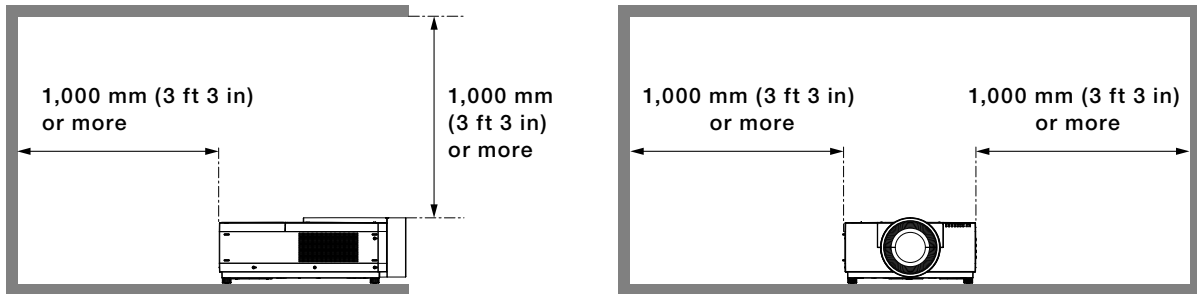

Direction of air intake and exhaust

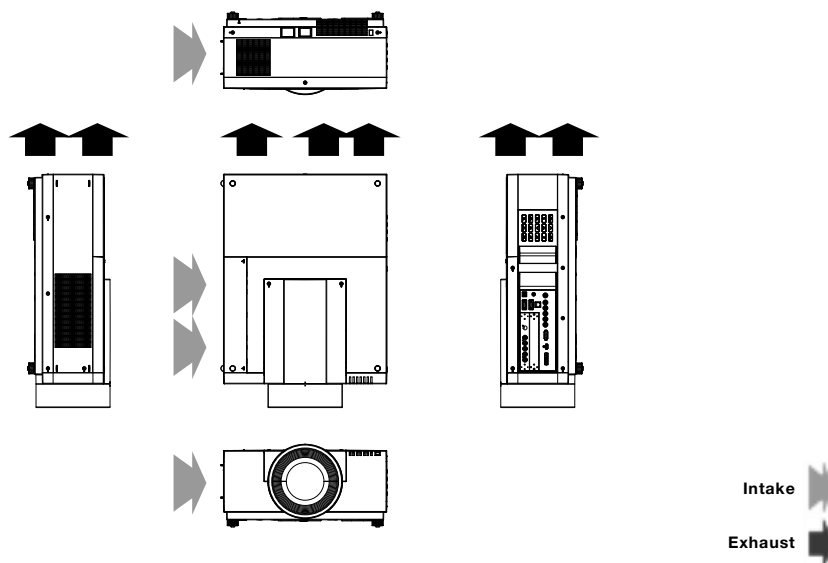

Operating the projector continuously

1. If the projector is to be operated continuously 24 hours, use the lamp relay mode. The projector cannot be operated continuously 24 hours in dual-lamp mode.
2. The lamp replacement cycle duration becomes shorter if the projector is operated repeatedly for short periods.

Weights and dimensions shown are approximate. Specifications and appearance are subject to change without notice.
Product availability differs depending on region and country. This product may be subject to export control regulations.

All other trademarks are the property of their respective trademark owners.